

INTRODUCTION

Accurate measuring and marking are the secrets to success for many projects around the home and garden.

Measuring and marking out help you to work accurately, and are important in the costing of large jobs around the house and garden.

Most products are now sold in metric quantities, but some are still in the imperial system. Always work in one system only - changing between the two is confusing and often inaccurate. Tapes and rules are usually marked in both systems of measurement.

SKILL LEVEL ●●●●●

Basic measuring and marking require very little skill, but always double check your results. Sometimes it's handy to have an assistant with you.

SAFETY FIRST

Retractable rules can sometimes snap back quickly, so take care. When marking with a knife, keep your fingers away from the blade, and don't apply excessive pressure.

TO COMPLETE THIS PROJECT YOU WILL NEED...

- Combination Square
- Craft or Marking Knife
- Flexible Rule
- Spirit Level
- Steel Or Wooden Rule
- Try Square
- Marking/Mortise Gauge
- Straightedge

HOW TO: MEASURING & MARKING

1 - PLANNING THE WORK

If you are measuring a large area, such as a lawn or patio, have ready-cut pegs to hand for driving in at the important points.

Working with an assistant helps with the measuring and also with checking calculations.

When measuring for smaller projects, using timber, man-made boards, plasterboard and other sheet materials, try to work on a clean surface in good light with all your tools close to hand.

Always allow a margin for wastage and error when calculating materials. This is often better than having to re-order or spoiling the job by skimping.

2 - MEASURING LARGE AREAS

Where it is important to check the right angles, such as for the base of a shed or greenhouse, or for a formal design with block paving etc., measure the diagonals to ensure complete accuracy. When the diagonals are equal, your base is said to be square. ①

The area of a large, irregular shape can be approximated by measuring square or rectangular areas within it and adding the measurements of these areas together. Make an allowance for the small, irregular areas left at the edges. ②

To find the exact area of an irregular shape, first measure the outside with a flexible tape or piece of string, and call this the circumference. Then calculate as though you were dealing with a circle.

Use the formula πr^2 to calculate the area of a circle, where $\pi=3.14$ and r =radius of circle (the radius is the length of a straight line from the centre to the edge of the circle).

Run a piece of string along irregular or curved edges if you need a quick linear measurement, for garden edging, for example.

3 - WORKING WITH A STRAIGHTEDGE

Straightedges are used mostly to transfer measurements accurately across areas longer than the rule being used. Another use for them is to check that your material or surface is flat. Straightedges are long metal rules that may be calibrated or plain.

The best way to check that a straightedge is accurate is to hold it by one end and look down it. Any curve is obvious.

A straightedge can also be used to cut against with a craft knife, such as when cutting paper, leather, cardboard or plasterboard.

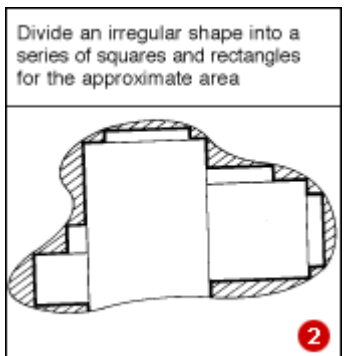
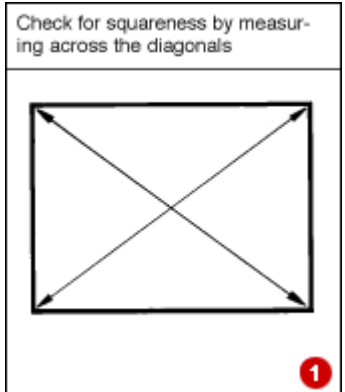

HOW TO: MEASURING & MARKING

4 - MARKING OUT

Measurements can be marked in various ways, depending on how accurate they need to be. A felt-tipped pen is easily read, and can be used where accuracy is not too critical. A carpenter's pencil is also ideal for easy-to-read measurements.

An ordinary hard lead pencil with a well-sharpened point is fairly accurate for most marking jobs, and it is quite easily rubbed out when required.

For very fine work to be cut, use a marking knife or a craft knife. These not only mark but sever the fibres very slightly to enable further cutting to be very exact. ③ The severed fibres leave a whisker-free cut edge.

Marking knives have the advantage of leaving no messy marks at all on the surface of the material.



5 - MARKING WITH A BENCH RULE

Bench rules come as either rigid or flexible. The flexible ones are handy for measuring curved surfaces, although very tight curves should be measured with a tape.

Steel rules are very useful, but they do have a tendency to slip on smooth surfaces. Hold the rule down well, with your fingers spread wide along the rule. ④

Using a rigid rule held on edge, with your fingers against the edge of the material being cut, is a quick way to step off the width. ⑤

Where possible, always measure from a clean, prepared edge. 'Measure twice, cut once' is good advice.



6 - DIVIDING INTO EQUAL PARTS

The simplest way to divide the work equally is to hold your rule diagonally across the surface and decide how many divisions you want to make. Be sure that the end of the rule is level with the edge of the material and the divisions will fall equal automatically. This is very handy for marking out dovetails and other joints. ⑤



HOW TO: MEASURING & MARKING

7 - USING SQUARES

Squares are used to produce a line at right-angles to an edge and to transfer one measurement to the opposite side of the material or perhaps all the way round. In this way, they save having to measure each face. They must always be used against a flat, planed edge.

The most basic square is the try square. Use a pencil or marking knife to mark your line against the steel edge. **7**

The try square is also used to check that faces are at 90 degrees to each other. The stock of the square is laid flat against one face of the work and a check is made visually to see if light appears under the steel edge. **8** If it does, more planing is necessary on the opposite side to the light, to square up the work. The try square is also used to check internal and external angles of assemblies.

A combination square has several uses. Most can be used as either internal or external try squares, mitre squares, depth gauges, straightedges and steel rules. They are usually fitted with a small spirit level. They are also very useful for marking parallel lines. **9**

8 - SLIDING BEVEL

The sliding bevel is a specialised type of square, which is infinitely adjustable and which is used for marking and transferring pre-set angles. This is useful for setting out angles for corner cupboards, steps, dovetails and multi-sided picture frames. It is usually set either from an existing angle or by using a protractor. **10**

When using the sliding bevel it is essential to ensure that the stock of the tool is held firmly against the edge throughout. **11**

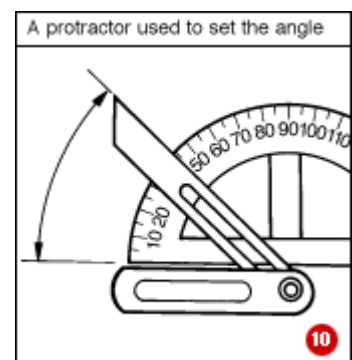
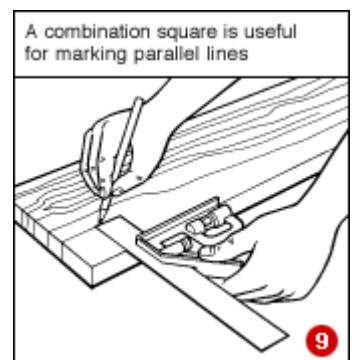
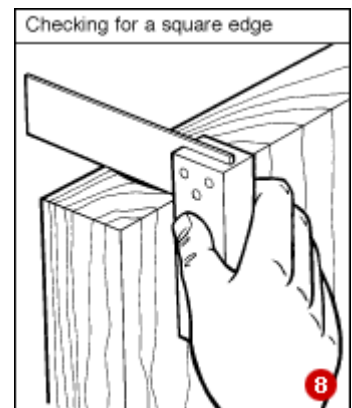
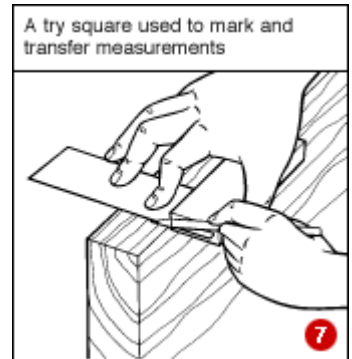

HOW TO: MEASURING & MARKING

9 - MARKING/MORTISE GAUGE

These two gauges are often combined in one tool although they can be purchased separately. Each gauge consists of a stock block which slides along a bar. The marking is done with a sharp steel point for a single line, or a pair of adjustable points to mark out a mortise. The stock of the tool is held against a flat square face and the tool pushed along the work away from the user, allowing the steel point(s) to score the wood.

When adjusting the gauge to the width of the mortise you need, set the points directly from the width of your chisel. **12**

Tighten sliding bevels well, and occasionally check that they haven't moved in use.

